

ZWX-180Acc3B

5G Cellular Whip antenna

The Joymax ZWX-180Acc3B antenna is a whip-style, IP67 rated, dipole antenna designed for 5G New Radio FR1, LTE, and Cellular IoT (LTE-M, NB-IoT) applications with broad bandwidth coverage from 617 MHz to 7125 MHz. The antenna also supports CBRS (3550 MHz to 3700MHz), Public Safety (4940 MHz to 4990 MHz), and a growing number of C-band applications.

The tilt/swivel design allows the antenna to be positioned for optimum performance and reduces the potential for damage from impact compared to a fixed whip design. The antenna attaches with an SMA plug (male pin) or RP-SMA Plug (female socket) connector.



Features

- Wide bandwidth 617MHz to 7.125 GHz
- Performance at 617 MHz to 960 MHz
 - VSWR: ≤ 2.5
 - Peak Gain: 1.5 dBi
 - Efficiency: 38%
- Hinged design with detents for straight, 45 degree and 90 degree positioning
- IP67 rated waterproof design
- Ground plane independence dipole design
- SMA plug (male pin) or RP-SMA plug (female socket)

Applications

- 5G NR FR1, 4G, 3G, 2G, CBRS
- Cellular IoT: LTE-M (Cat-M1), NB-IoT
- CBRS Private Network (3550 to 3700MHz)
- C-Band applications (3700 to 4200MHz)
- Public Safety networks (4940 to 4990MHz)
- Internet of Things (IoT) devices
- Networking routers / gateways

Ordering Information

Part Number	Description
ZWX-180ASA3B	5G/LTE Cellular Tilt/Swivel Whip Antenna with SMA plug (male pin) Connector
ZWX-180ARS3B	5G/LTE Cellular Tilt/Swivel Whip Antenna with RP-SMA plug (female socket) Connector

Available from Joymax Electronics and select distributors and representatives.

Table 1: Electrical Specifications

ZWX-180Acc3B	5G NR / LTE Bands (MHz)					
Frequency Range	617~960	1710~2690	3300~4200	4400~5000	5150~5850	5925-7125
VSWR (Max)	2.5	3.2	2.0	1.7	2.6	2.8
Peak Gain (dBi)	1.5	2.8	2.8	2.4	2.6	3.1
Average Gain (dBi)	-4.2	-3.6	-3.3	-3.6	-3.2	-3.6
Efficiency (%)	38	44	47	43	48	43
Polarization	Linear					
Radiation	Omni directional					
Max Power	1 W					
Wavelength	$\frac{1}{2}\lambda$					
Electrical Type	Dipole					
Impedance	50 Ω					

Electrical specifications and plots measured with the antenna in free space without ground plane.

Table 2: Mechanical Specifications

Parameter	Value
Connection	SMA Plug (male pin) or RP-SMA Plug (female socket)
Operating Temp.	-30°C to +70°C
Weight	23 g
Dimension	203mm (Straight) x \varnothing 13 mm
Antenna Color	Black
Ingress Protection	IP67

Packaging Information

The ZWX-180Acc3B antennas are individually sealed in a clear plastic bag. **Figure 1.** 300 pcs per carton, 320 mm x 250 mm x 230 mm (12.5 in x 9.8 in x 9.0 in), total weight 7.9 kgs (17.4 lb) Distribution channels may offer alternative packaging options.



1pcs antenna / 1 PE bag

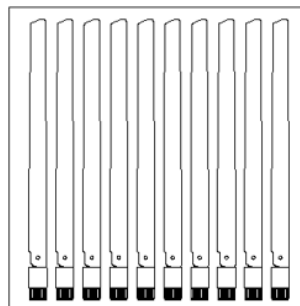

50pcs antenna / 1 Bigger PE bag

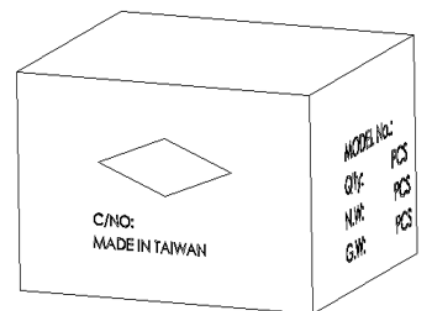

300pcs antenna / 1 Carton

Figure 1. Antenna Packaging

Product Dimensions

Figure 2 provides dimensions of the ZWX-180ACC3B. The antenna whip can be tilted 90 degrees, and has a detent at 45 degrees enabling the antenna to be oriented in any direction. The rotating base allows for continuous positioning through 360 degrees even while installed.

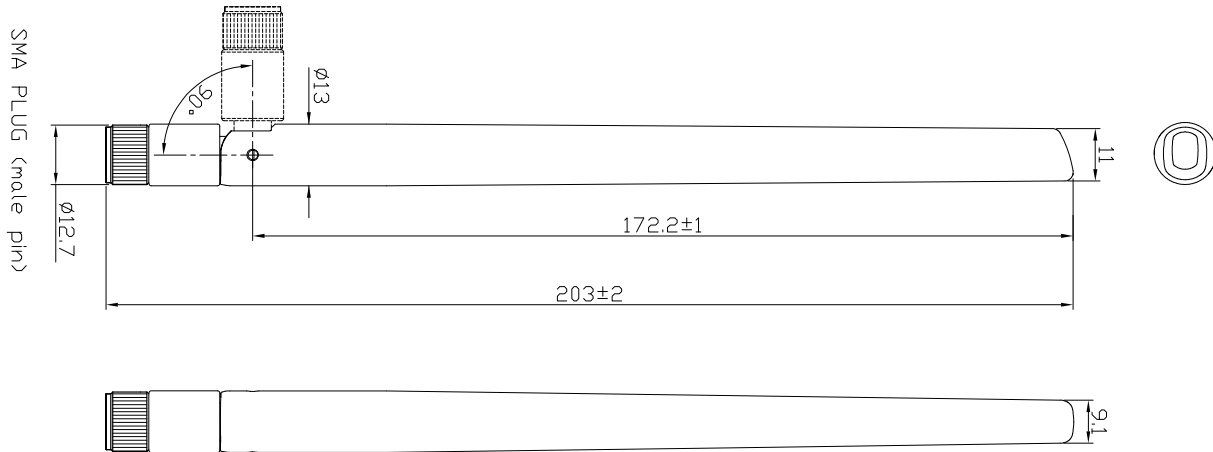

Figure 2. Antenna Dimensions

Antenna Orientation

The ZWX-180Acc3B antenna is characterized in 90 degrees bent antenna orientations as shown in Figure 3. The antenna orientation characterizes use of an antenna attached to enclosure-mounted connector which is connected by cable to the VNA. The charts on the following pages represent data taken with the antenna hanging free without ground plane.



Figure 3. Antenna Test Orientation

VSWR

Figure 4 provides the voltage standing wave ratio (VSWR) across the antenna bandwidth. VSWR is a function of the reflection coefficient, which describes the power reflected from the antenna back to the radio. A lower VSWR value indicates better antenna performance at a given frequency. Reflected power is also shown on the right-side vertical axis as a gauge of the percentage of transmitter power reflected back from the antenna.

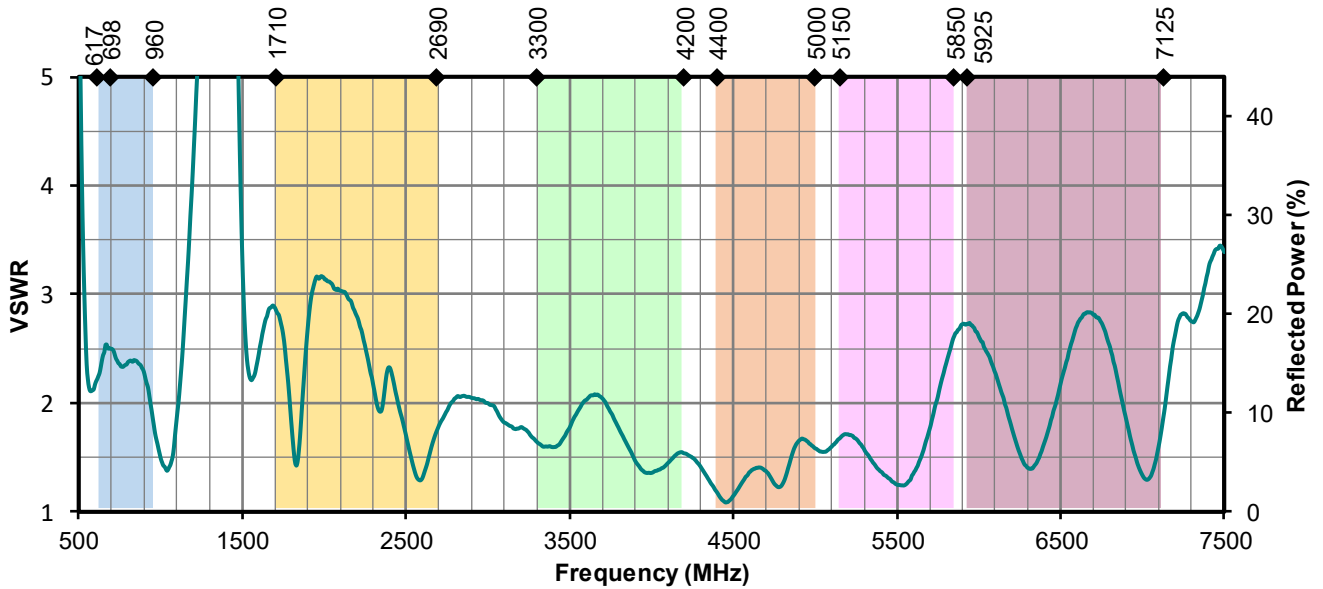

Figure 4. Antenna VSWR, free space no ground plane

Return Loss

Return loss (**Figure 5**), represents the loss in power at the antenna due to reflected signals. Like VSWR, a lower return loss value indicates better antenna performance at a given frequency.

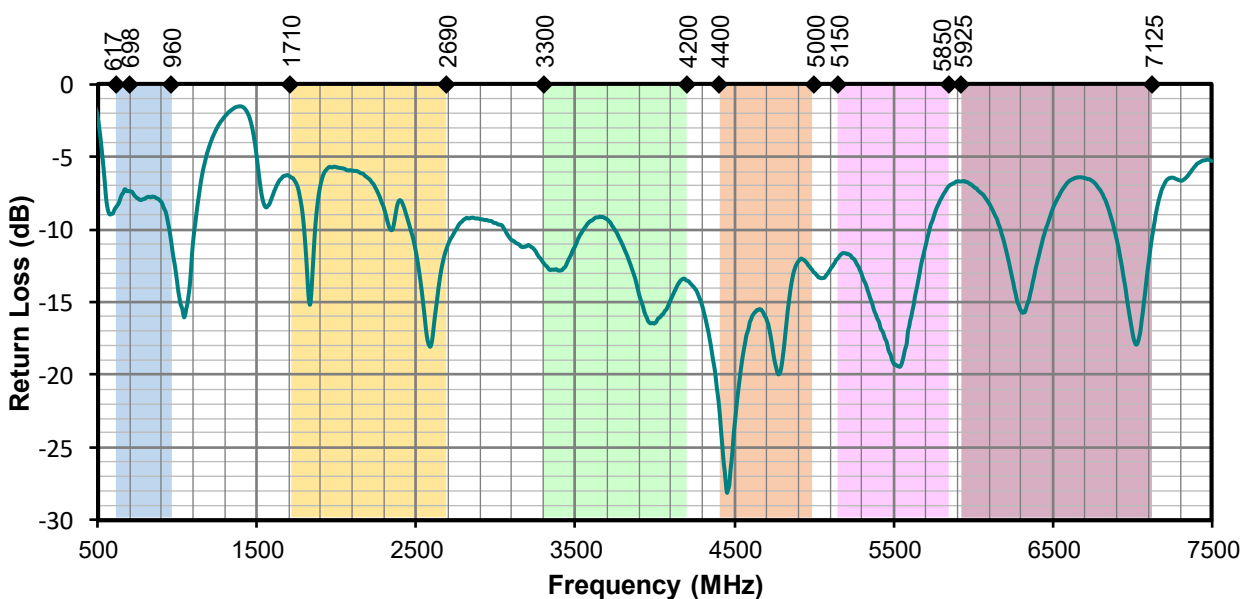

Figure 5. Antenna Return Loss, free space no ground plane

Peak Gain

The peak gain across the antenna bandwidth is shown in **Figure 6**. Peak gain represents the maximum antenna input power concentration across 3-dimensional space, and therefore peak performance at a given frequency, but does not consider any directionality in the gain pattern.

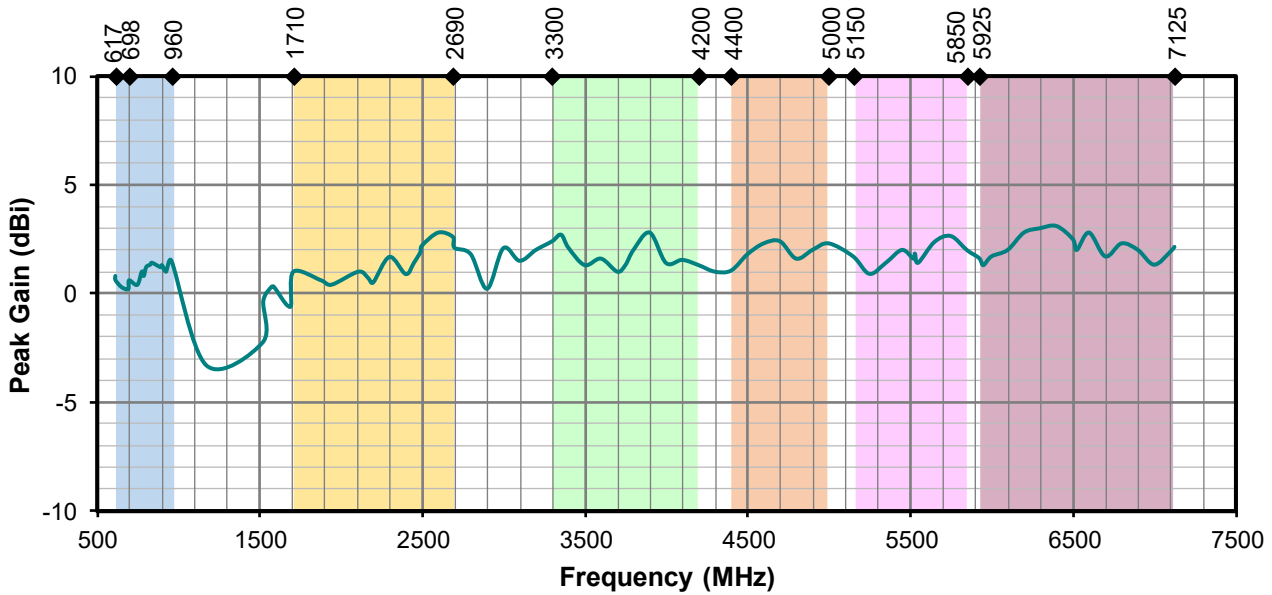

Figure 6. Antenna Peak Gain, free space no ground plane

Average Gain

Average gain (**Figure 7**), is the average of all antenna gain in 3-dimensional space at each frequency, providing an indication of overall performance without expressing antenna directionality.

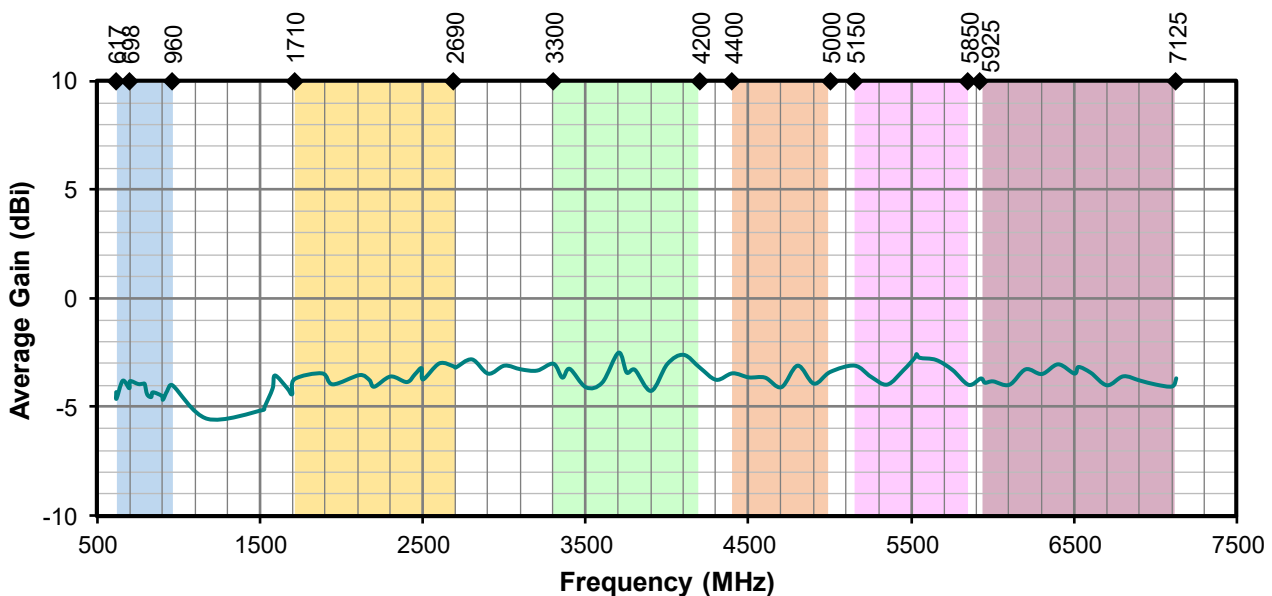

Figure 7. Antenna Average Gain, free space no ground plane

Radiation Efficiency

Radiation efficiency (**Figure 8**), shows the ratio of power radiated by the antenna relative to the power supplied to the antenna, expressed as a percentage, where a higher percentage indicates better performance at a given frequency. An ideal antenna has 100% efficiency. But in really world, usually an external antenna radiates only 50~60% of power supplied to it.

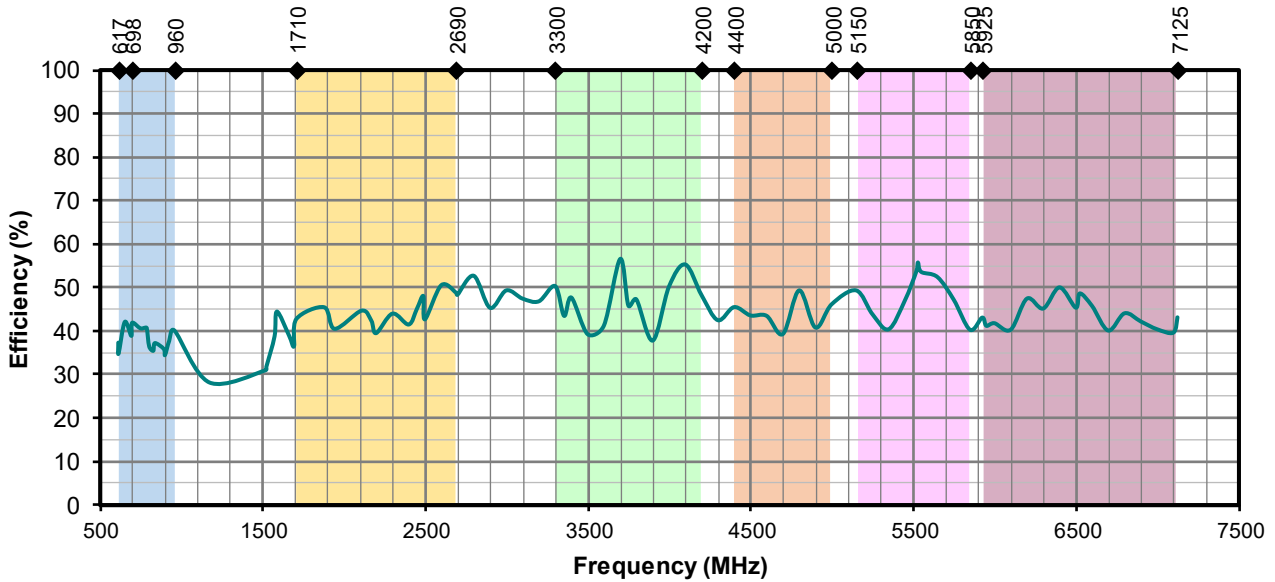
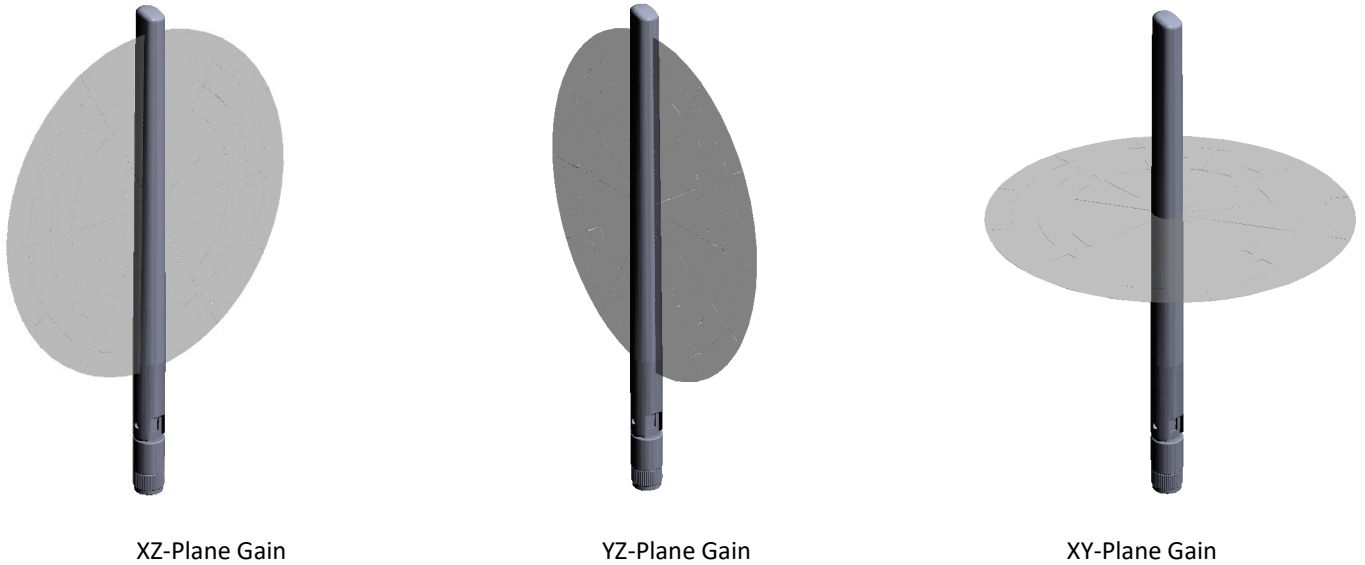

Figure 8. Antenna Efficiency, free space no ground plane

Radiation Patterns

Radiation patterns provide information about the directionality and 3-dimensional gain performance of the antenna by plotting gain at specific frequencies in three orthogonal planes. Antenna radiation patterns for a straight orientation are shown in **Figure 9** using polar plots covering 360 degrees. The antenna graphic at the top of the page provides reference to the plane of the column of plots below it.



617 MHz to 960 MHz (778 MHz)

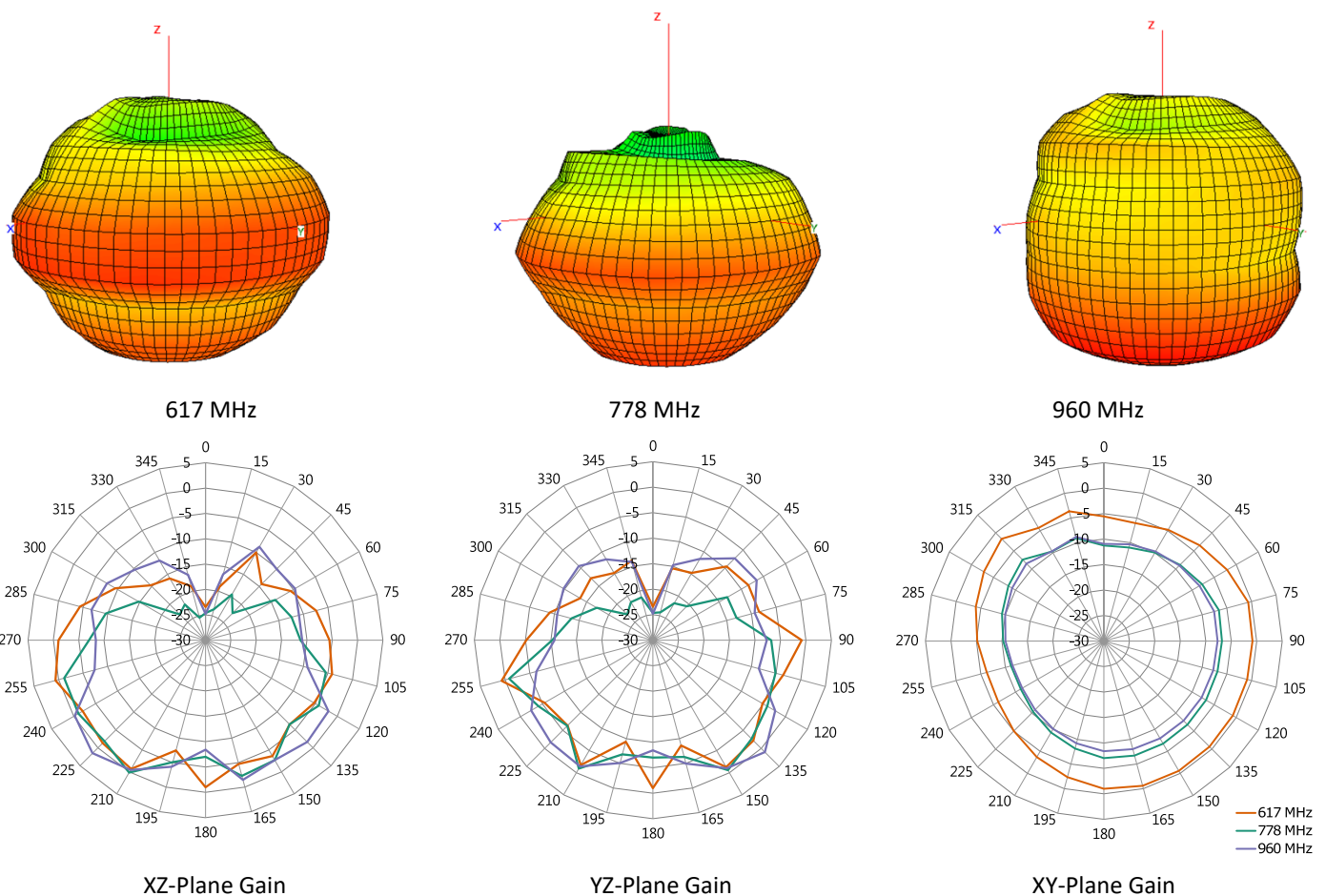
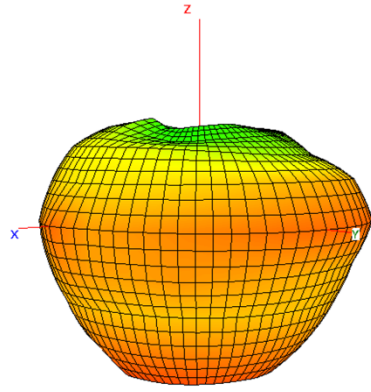
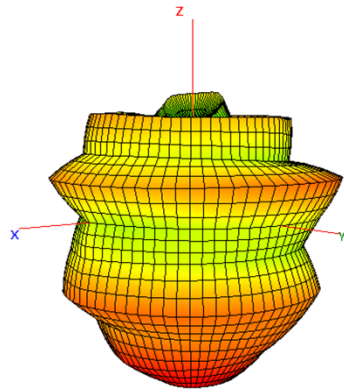

Figure 9. Antenna Radiation Patterns, free space no ground plane

1710 MHz to 5000 MHz (3355 MHz)



1710 MHz



3355 MHz

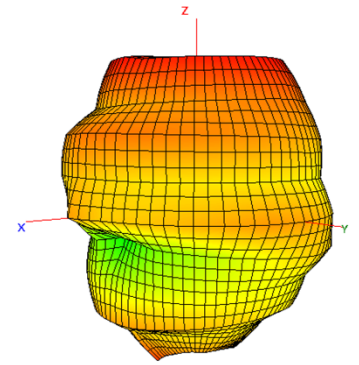

5000 MHz

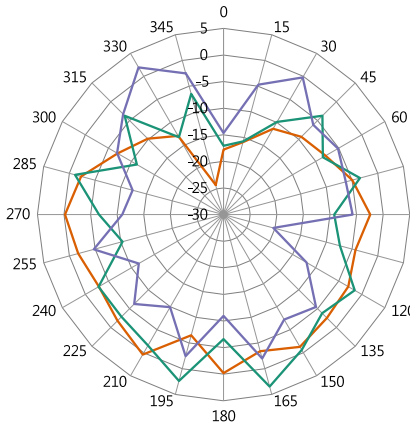

XZ-Plane Gain

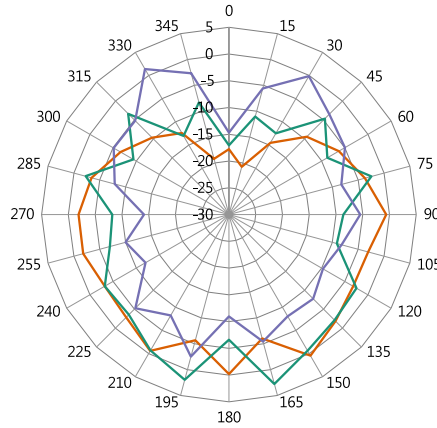

YZ-Plane Gain

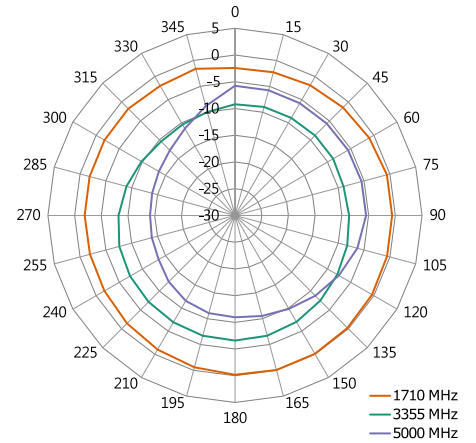

XY-Plane Gain

5150 MHz to 5850 MHz (5550 MHz)

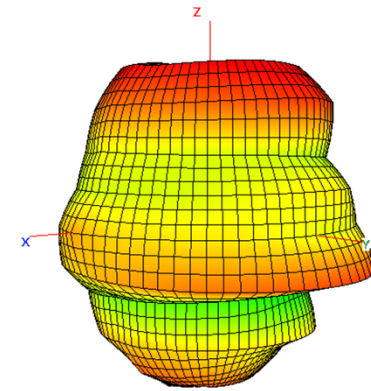

5150MHz

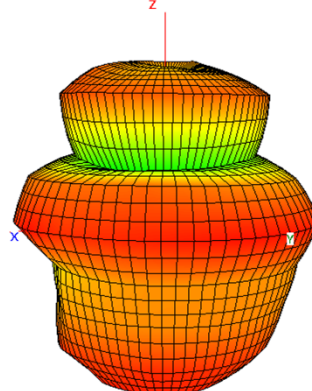

5500 MHz

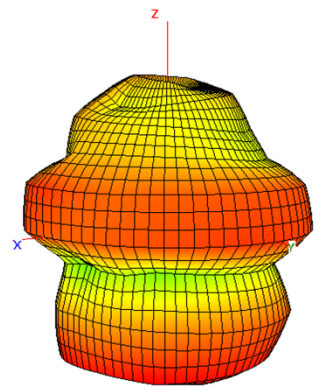

5850 MHz

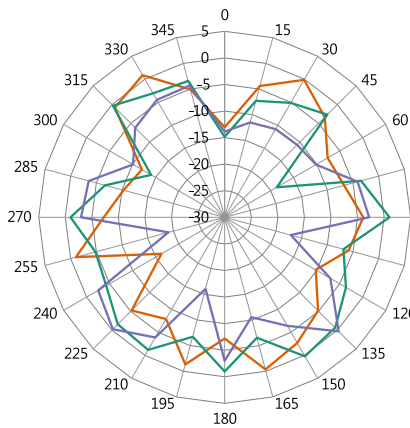

XZ-Plane Gain

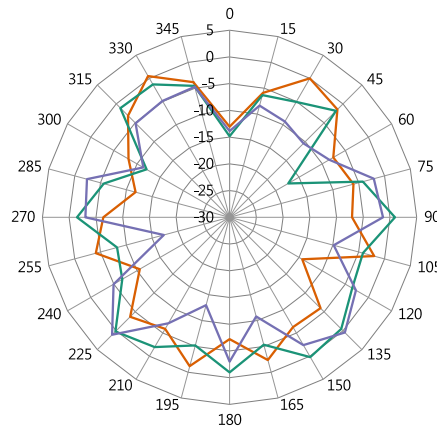

YZ-Plane Gain

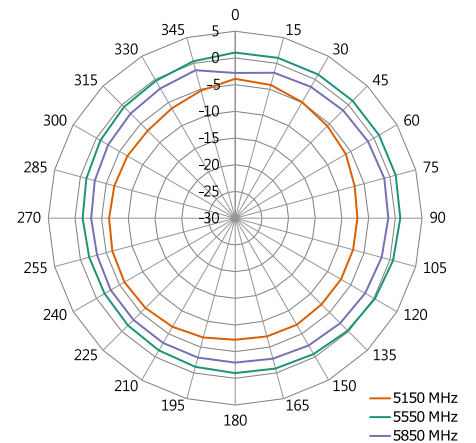

XY-Plane Gain

5925 MHz to 7125 MHz (6525 MHz)

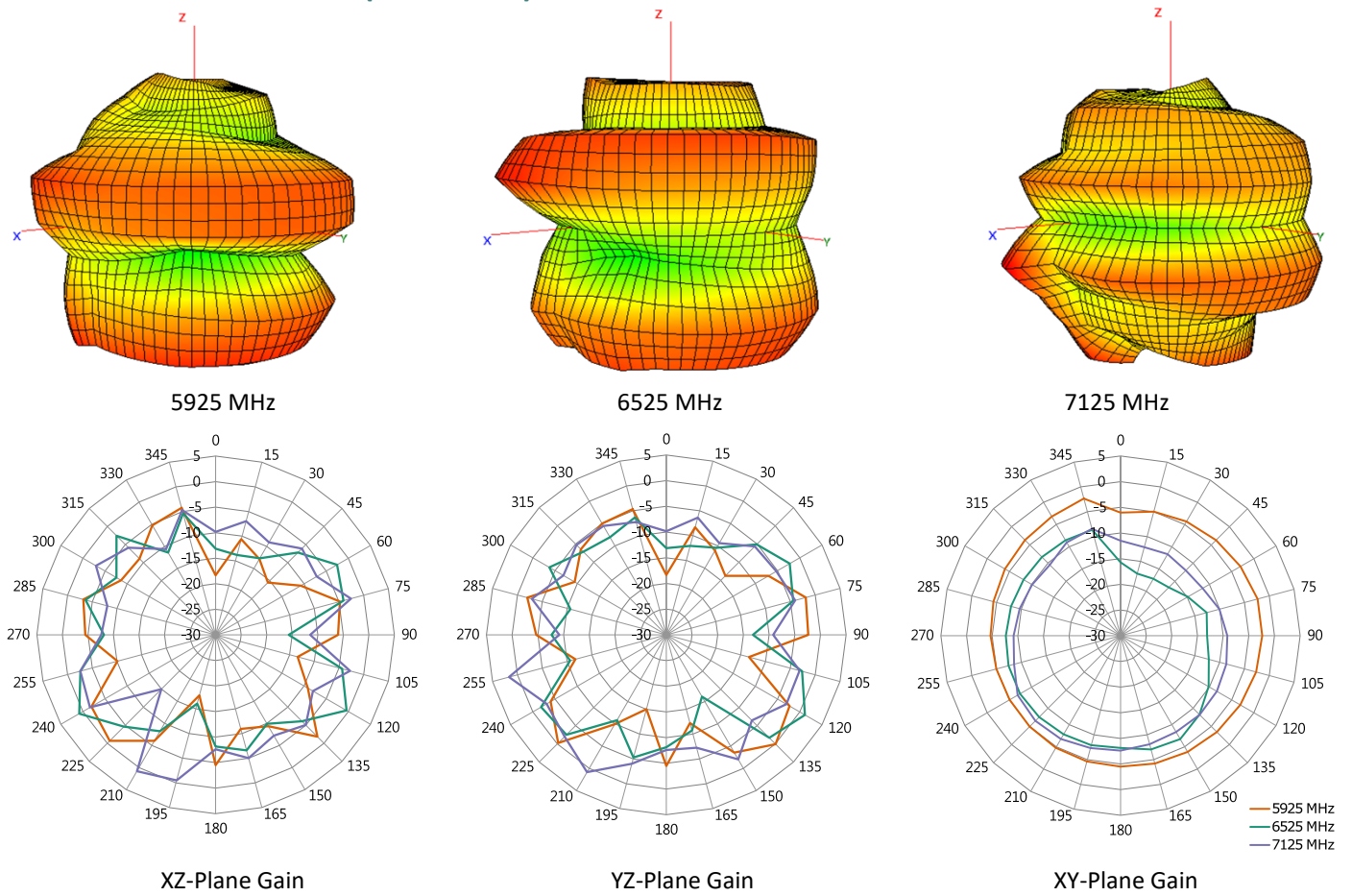

Figure 9-1. Antenna Radiation Patterns, free space no ground plane

Antenna FAQs

Q: What is an antenna?

An antenna is used for transmission or reception of radio signals in wireless communication.

Q: How do antennas work?

Electricity flowing into the transmitter antenna makes electrons vibrate up and down it, producing radio waves. The radio waves travel through the air at the speed of light. When the waves arrive at the receiver antenna, they make electrons vibrate inside it.

Q: Does antenna size matter?

A bigger antenna, properly designed, will always have more **gain** than a smaller one. And it will be the best kind of **gain**, much better than using a small antenna and simply over-amplifying it, because a small antenna just won't pull in truly weak signals like this gigantic one will.

Q: What is the advantage of external antennas?

External antennas usually offer **better bandwidth** and **high performance** due to the nature of their larger size. This often results in a higher rated **gain** (dBi) than their internal counterparts. Due to its smaller size, an internal antenna would not function well to support lower frequencies.

Ease of integration – an external antenna requires fewer design resources and shorter time to integrate to allow for a more rapid time-to-market. An internal antenna's performance is influenced by device environment – PCB ground plane, nearby metal part, and enclosure. That would require much more effort such as impedance matching network to complete antenna design

Q: Why is most antenna impedance 50 Ohm?

50 Ohm is an industry standard of coax cables and power amplifiers. It was chosen as a tradeoff between maximum power handling for the transmit coax and the copper losses. The optimum would have been anyway in the range of **30 to 100 ohm** with average at 50 Ohm

Q: Why does GNSS require RHCP (Right-hand-circularly-polarized) antennas?

Satellite's signal has a low power density, especially after propagating through the **atmosphere** (**ionosphere** affect radio wave). Polarized waves oscillate in more than one direction, which deliver satellite's signal to receiver on Earth surface more effectively.

Website: <https://www.joymax.com.tw>
Offices: 5, Dong-Yuan 2nd Road, Zhong-Li Dist., Tao-Yuan City 32063 Taiwan (R.O.C.)
Phone: +886 3 433 5698
E-MAIL: info@joymax.com.tw

Joymax Electronics reserves the right to make changes to the product(s) or information contained herein without notice. No liability is assumed as a result of their use or application. No rights under any patent accompany the sale of any such product(s) or information.

EnJOY MAX Wireless is a registered trademark of Joymax Electronics Co., Ltd. Other product and brand names may be trademarks or registered trademarks of their respective owners.

Copyright © 2024 Joymax Electronics
All Rights Reserved.

01/24 RevA